

BENDIX/KING KT-73 MODE-S TRANSPONDER - MAINTENANCE PRACTICES

1. General

- A. This section gives removal and installation procedures for the KT-73 Mode-S transponder.
- B. The KT-73 transponder is in the center radio panel.

2. KT-73 Transponder Removal/Installation

- A. Remove the KT-73 transponder (Refer to Figure 201).
 - (1) Disengage the XPDR 1 circuit beaker on the left circuit breaker panel.
 - (2) Put a 3/32-inch hex wrench through the front panel of the transponder to get access to the lock mechanism.
 - (3) Turn the hex wrench counterclockwise to loosen the transponder in the mounting rack.
 - (4) Remove the hex wrench.
 - (5) Pull the transponder from the mounting rack.
- B. Install the KT-73 Transponder (Refer to Figure 201).
 - (1) Put the KT-73 transponder in position in the mounting rack.
 - (2) Use the 3/32-inch hex wrench to lock the transponder.
 - (3) Turn the hex wrench clockwise to lock the transponder in position.
 - (4) Remove the hex wrench.
 - (5) Engage the XPDR 1 circuit breaker on the left circuit breaker panel.
 - (6) Do the Transponder Functional Check. Refer to Dependent Position Determining - Inspection/Check.

3. Transponder Antenna Without Cargo Pod Removal/Installation

NOTE: The airplane can have one or two transponder antennas. The removal and installation procedures for the transponder antennas are typical. For the Model 208, the transponder antennas are located on the bottom of the airplane at FS 237.00, RBL 12.25 for transponder antenna 1, and FS 237.00, LBL 12.25 for transponder antenna 2. For the Model 208B, the transponder antennas are located on the bottom of the airplane at FS 285.00, RBL 12.25 for transponder antenna 1, and FS 285.00, LBL 12.25 for transponder antenna 2.

- A. Remove the Transponder Antenna (Refer to Figure 202).
 - (1) Disengage the XPDR 1 transponder circuit breaker, on the lower left circuit breaker panel.
 - (2) Remove the screws from the transponder antenna.
 - (3) Carefully pull the transponder antenna away from the skin.
 - (4) Disconnect the coax connector from the transponder antenna.
 - (5) Remove the transponder antenna from the airplane.
- B. Install the Transponder Antenna (Refer to Figure 202).
 - (1) Make sure that the mounting surface area and the transponder antenna are clean and free of old sealant and contamination. Refer to Chapter 20, Fuel, Weather and High-Temperature Sealing - Maintenance Practices.
 - (2) Put the transponder antenna in position near the skin.
 - (3) Connect the coax connector to the transponder antenna.
 - (4) Install the screws in the transponder antenna and attach the transponder antenna to the skin.
 - (5) Do a check of the electrical bonding. Refer to Chapter 20, Electrical Bonding - Maintenance Practices.
 - (6) Engage XPDR 1 transponder circuit breaker on the lower left circuit breaker panel.
 - (7) Do the Transponder Functional Check. Refer to Dependent Position Determining - Inspection/Check.
 - (8) Fillet seal the exterior mating surfaces with Type 1 sealant. Refer to Chapter 20, Fuel, Weather and High-Temperature Sealing - Maintenance Practices.

4. Transponder Antenna With Cargo Pod Removal/Installation

NOTE: The airplane can have one or two transponder antennas. The removal and installation procedures for the transponder antennas are typical. For the Model 208 and the Model 208B, the transponder antennas are located on the bottom of the cargo pod at FS 154.30, LBL 12.25 for transponder antenna 1 and FS

154.30, RBL 12.25 for transponder antenna 2.

- A. Remove the Transponder Antenna (Refer to Figure 203).
- (1) Disengage XPDR 1 transponder circuit breaker on the lower left circuit breaker panel.
 - (2) Open the cargo pod compartments to get access to the transponder antenna.
 - (3) Disconnect the coax connector from the transponder antenna.
 - (4) Remove the screws, washers, and nuts from the transponder antenna.
 - (5) Carefully pull the transponder antenna away from the cargo pod.
 - (6) Remove the transponder antenna from the airplane.
- B. Install the Transponder Antenna (Refer to Figure 202).
- (1) Make sure that the mounting surface area and the transponder antenna are clean and free of old sealant and contamination. Refer to Chapter 20, Fuel, Weather and High-Temperature Sealing - Maintenance Practices.
 - (2) Put the transponder antenna in position on the cargo pod.
 - (3) Install the screws, washers, and nuts in the transponder antenna.
 - (4) Connect the coax connector to the transponder antenna.
 - (5) Do a check of the electrical bonding. Refer to Chapter 20, Electrical Bonding - Maintenance Practices.
 - (6) Engage XPDR 1 transponder circuit breaker on the lower left circuit breaker panel.
 - (7) Do the Transponder Functional Check. Refer to Dependent Position Determining - Inspection/Check.
 - (8) Fillet seal the exterior mating surfaces with Type 1 sealant. Refer to Chapter 20, Fuel, Weather and High-Temperature Sealing - Maintenance Practices.
 - (9) Close the cargo pod compartments.

Figure 201 : Sheet 1 : Bendix/King KT-73 Transponder Installation

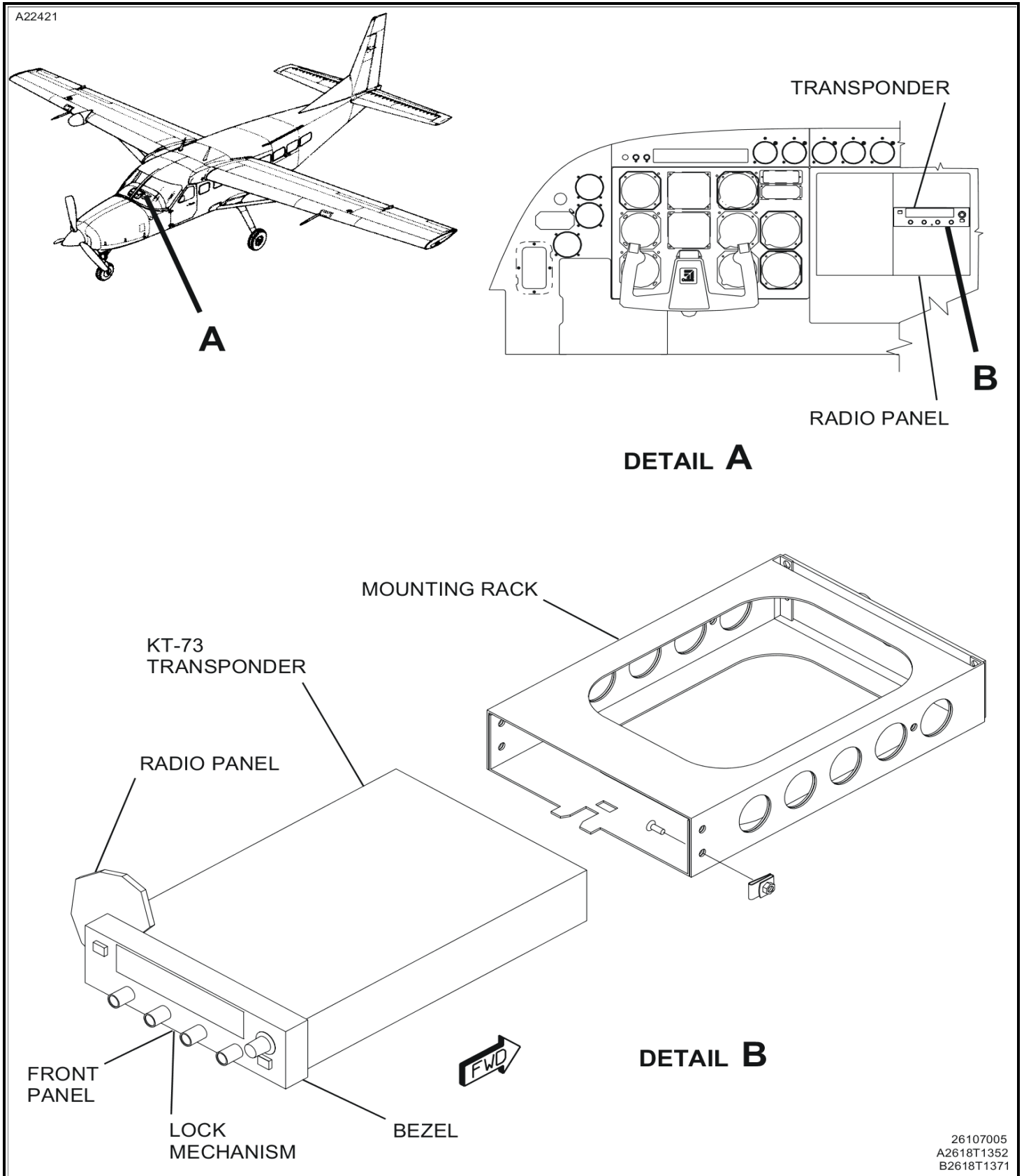

Figure 202 : Sheet 1 : Transponder Antenna without Cargo Pod

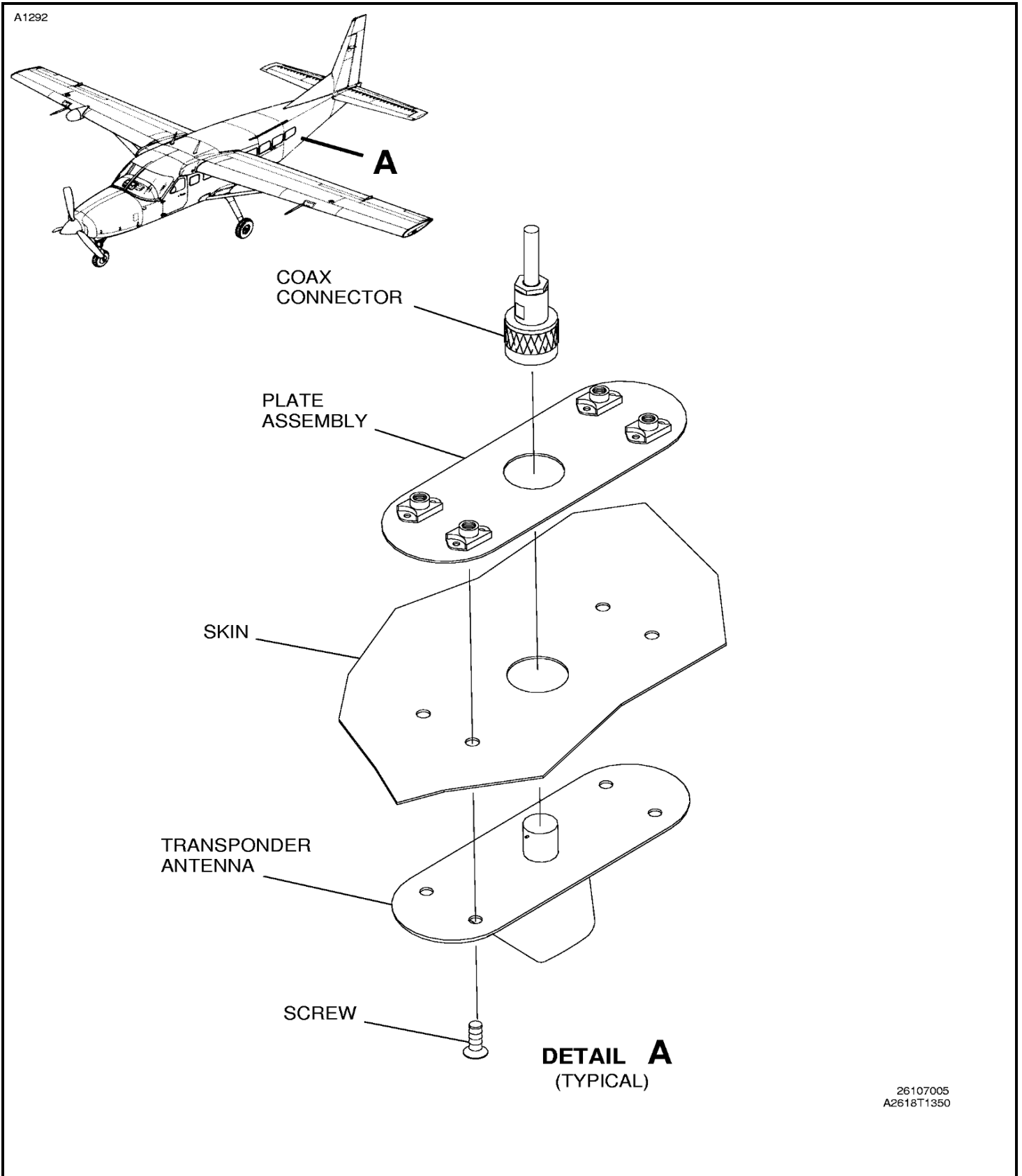

Figure 203 : Sheet 1 : Transponder Antenna with Cargo Pod

